



# DSN100

## DEFENSE SWITCHED NETWORK ADJUNCT

### INSTALLATION & OPERATING GUIDE

COMCODE: 407559285

PEC CODE: 8804-025



### ***Overview of the DSN Network***

The DSN (Defense Switched Network), a part of the Defense Communications System, is a military network that provides preemption capabilities for calls related to national defense.

The DSN interface, when added to a PBX (Private Branch Exchange), allows attendants and other users of the system to enter the military network by dialing an access code. Users can get assistance on outgoing DSN calls by dialing an attendant-assistance code.

Calls on the DSN network may be precedence or non-precedence calls. Precedence calls are routed over trunks called precedence capable trunks. These calls can be routed through the network without attendant assistance.

### ***Characteristics of the Network***

DSN Network has the following characteristics that distinguish it from other types of networks:

A numbering plan that defines 7 digit dialing for DSN calls inside a system and 7 or more digits for DSN calls outside a system.

DSN calls carry with them one of five precedence levels:

- 1] Routine
- 2] Priority
- 3] Immediate
- 4] Flash
- 5] Flash Override

Calls of one precedence level may be preempted automatically or manually when a call of a higher precedence level is attempting completion.

Incoming precedence calls to an extension that does not answer in a specified period of time (from 10 to 60 seconds) are routed to an extension available 24 hours a day. The extension must then attempt to complete the call.

***Terms used with  
the DSN Network***

The following terms are used in this guide and/or other DSN documentation; they should be familiar to all DSN users.

**Preemption** - the disconnecting of an established call and re-seizing of the same line or trunk by a call of a higher precedence level when no idle circuit is available to complete the higher precedence call.

**Precedence** - a rank assigned to indicate the degree of preference to be given in processing and protecting DSN calls; originators of precedence calls may elect to use their highest authority level or any lesser precedence level.

**Flash Override (FO)** - the highest precedence level for DSN calls.

**Flash (FL)** - the second highest ranking precedence level for DSN calls.

**Immediate (IM)** - the third highest ranking precedence level for DSN calls.

**Priority (PR)** - the fourth highest ranking level for DSN calls.

**Routine (RT)** - the lowest ranking precedence level for DSN calls.

**Dial Service Assistance (DSA) operator** - an operator associated with DSN switching center who provides services such as information, interception, random conferencing, and precedence calling assistance to PBX attendants on DSN calls.

***Programming  
the DSN-100***

To program setup information into the DSN-100, it will be necessary to make all cross connections and to program trunk translations in the PBX. See examples of PBX translations for analog interface.

After all other work is complete, plug in the power supply. **Note!** PBX ground must be connected to the common ground of the power supply. The amber led labeled "program" should blink if the unit is new. If it was previously programmed the green "idle" led will be blinking. In that case, momentarily push the recessed program switch labeled "pgrm mode". Before programming, it will be necessary to have the following informa-

tion available:

- 1] Is the trunk precedence inward ?
- 2] Is the trunk precedence outward ?
- 3] Don't answer transfer time.
- 4] Number of digits in dial plan.
- 5] Transfer station number.

Remove the FAC plug from the DSN-100. If the unit was wired to it's 56 pin connector, temporarily remove the "M" signaling wire (pin 40). From a touch tone phone, dial the trunk access code. After the unit answers, enter the following information in the exact order.

- 1] Precedence in            Yes = 1    No = 0
- 2] Precedence out        Yes = 1    No = 0
- 3] Transfer time            01 - 99 seconds    (Must be 2 digit)
- 4] Number of digits in dial plan (3, 4, 5)
- 5] Transfer station number (Not "0")
- 6] " # " ends programming session.

☞ *Example: 1, 1, 30, 4, 2006, #*

Precedence in, precedence out, 30 second transfer, 4 digits in dial plan, 2006 call coverage number.

After all information has been entered and the trunk returned to idle, the "program" led will turn off and the "idle" led will blink.

### ***Answering an incoming precedence call***

Precedence calls normally come directly to voice terminals in the PBX rather than to attendant consoles. However, when an incoming call to a voice terminal cannot be connected within some preset period (30 seconds is a typical value), the call is routed to another voice terminal to be answered. The procedure for answering a precedence call at a console is the same as for any other type of call.

### ***Placing an outgoing precedence call***

An attendant or a voice terminal user can place a precedence level call in accordance with local practices. To place a call, the user must dial the DSN trunk access code followed by the precedence level requested and the DSN phone number (7 to 10 digits). It is not neces-

sary to have a special 16 button dial to place precedence level calls. The precedence numbers and their corresponding levels are as follows:

- 4 - Routine (RT)
- 3 - Priority (PR)
- 2 - Immediate (IM)
- 1 - Flash (FL)
- 0 - Flash Override (FO)

A user must dial a precedence level on all calls using a precedence trunk, even routine calls. The ability of PBX users to place calls can be controlled via class of service and trunk restriction.

A voice terminal user who gets busy tone after placing an outgoing precedence call should hang up, and then call the local attendant for assistance. The attendant may be able to place the call on a higher precedence level trunk than a voice terminal user can access. The attendant may also use voice pre-emption to request use of a trunk.

***Specifications***

<b>SIZE</b> .....	6.12"L x 1.44"W x 5.63"H
<b>WEIGHT</b> .....	6.2oz
<b>OPERATING VOLTAGE</b> .....	-48VDC
<b>POWER CONSUMPTION:</b> .....	50mA

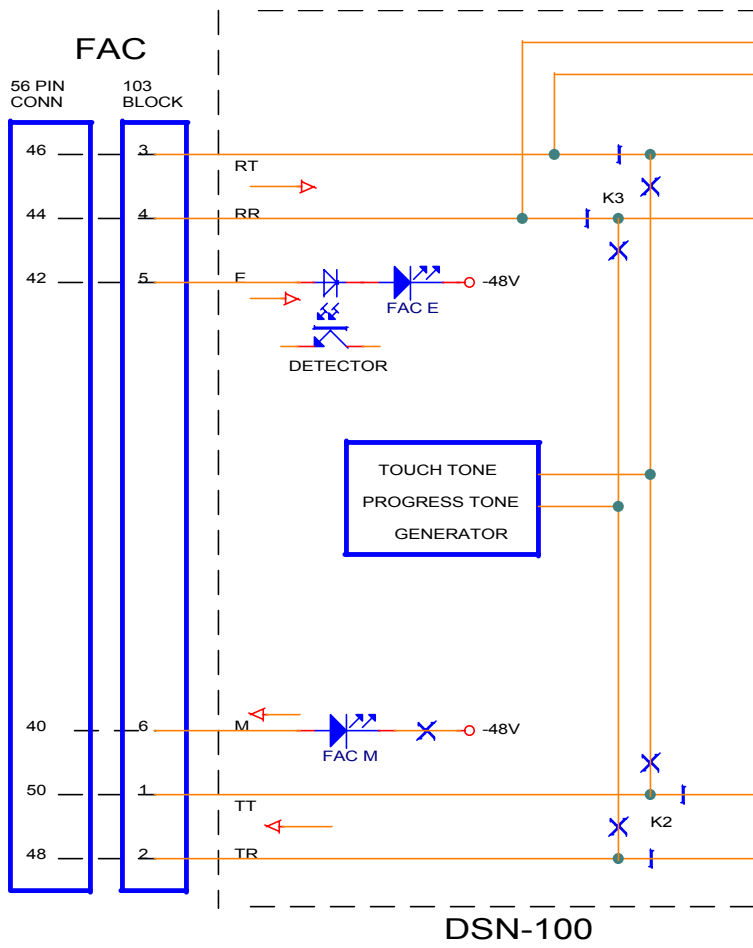

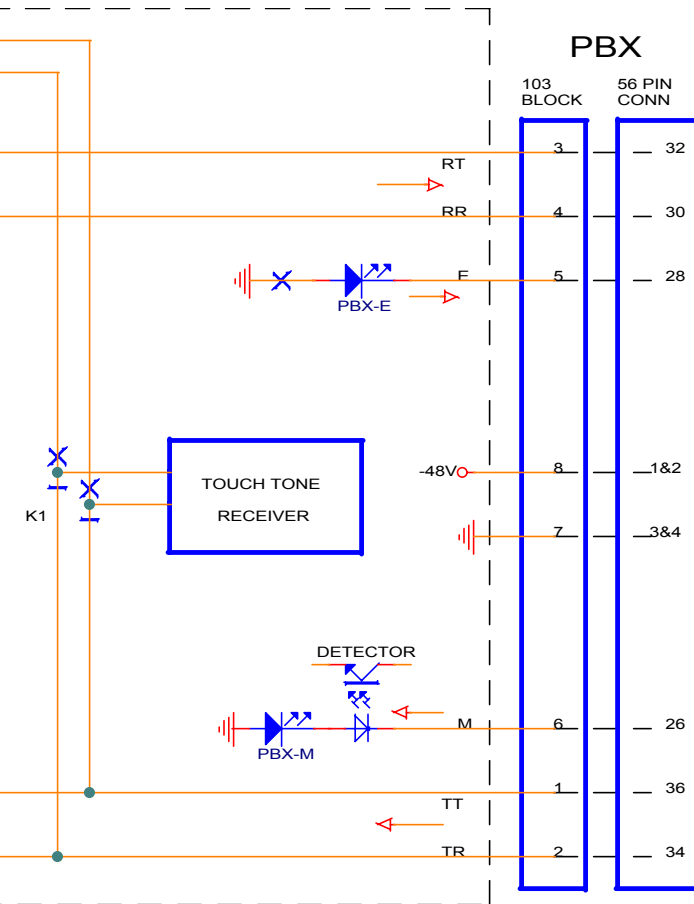

Lucent Technologies		
Title AUTOVON TRUNK CIRCUIT		
Size A	Document Number DSN_100.S1	Rev
Date:	Wednesday, July 31, 1996	Sheet 1 of 1

# Avaya Communication

---

## Tie Trunk Translations

Group Number:\*\* Trunk Group Page 1  
Group Name:DSN Precedence Group Type:tie CDR Reports:\*  
Direction:two-way Cor:1 N:\_\_\_ TAC:\*\*  
Outgoing Display:Y Trunk Signal Type:\_\_\_  
Dial Access:y Busy Threshold:99 Night Service:\_\_\_  
Queue Length:0 Incoming Destination:\_\_\_  
Comm Type:Voice Auth Code:n

### Trunk Parameters

Trunk Type(in/out):wink/wink Incoming Rotary Timeout(sec):5  
Outgoing Dial Type:tone Incoming Dial Type:tone  
Wink Timer:300 Disconnect Timing(msec):250  
Digit Treatment:\_\_\_ Digits:\_\_\_  
Signal Bit Inversion:none  
Connected to Toll? n STT Loss:normal DTT to DCO Loss:normal  
Incoming Dial Tone? n  
Answer Supervision Timeout:10

### Trunk Features

Page 2

ACA Assignment? N  
Measured:none Internal Alert? n  
Used for DCS? n Data Restriction? n  
Maintenance Tests? n Glare Handling none  
Supress # Outpulsing? n

Page 3

Use all default values

Page 4

### Trunk Groups

#### Group Member Assignments

Port	Name	Night	Mode	Type	Ans Delay
1:xxxx	DSN Precedence		E&M	T1 stan	
2:					
3:					
4:					
5:					
6:					
7:					
8:					
9:					



Starcom Incorporated

3303 North Dixie Highway  
Boca Raton, FL. 33431

phone: (561) 392-7001 ★ fax: (561) 392-7003 ★ email: info@starcom-inc.com ★ internet: www.starcom-inc.com