

AVAYA

VS-100

VOICE SYNTHESIZER

USERS GUIDE

COMCODE: 408 338 101

PEC CODE: 8800-135



Description

The VS100 is a voice synthesizer that works with Lucent two wire DCP digital telephones. It is used to voice the set display information and some of the indicator conditions. It works with Lucent Callmaster sets, 8400 series 2 wire sets, 6400 series sets and 302 consoles (The voiced information on 302 consoles is limited to the display).

The voiced information on digital telephones includes the display and the message waiting indicator. Since information is automatically voiced each time the display is updated, messages at times will voice more than once.

Using the VS100 touch tone dial, a search can be requested to locate lines on hold, or selected lines can be queried to determine if that line is idle or busy.

The VS100 is not able to process information associated with a DSS adjunct.

The VS100 works in conjunction with the Lucent 645 Digital to Analog converter (DAC). The DAC input connects in parallel with a two wire digital telephone. It monitors the data on the digital set and converts it to serial RS232 for the VS100. The DAC converter only processes data sent from the PBX to the telephone. It does not process data sent from the telephone to the PBX. Therefore, when placing an outgoing call the dialed digits are not voiced because the displayed digits are sent from the telephone to the PBX. After the caller completes dialing, the display is updated with the information of the called party and this information is voiced.

Since the Dual port DAC has just one serial output, only one port on the DAC may be used for this application.

Installation

The voice terminal must be on a 2-wire port. Refer to the diagram on page 3 and the following instructions.

Voice terminal

Voice terminal data is supplied to the DAC unit through a bridged connection on pair 1 of the line cord.

- 1- Disconnect the existing line cord from the wall jack (PBX). Do not remove the line cord from the set.
- 2- Connect this line cord from the voice terminal to the jack block/interface cable (MA24).
- 3- Connect the D8W-87-7 cord supplied to the wall jack and the remaining jack on the MA24.

CONNECTION DIAGRAM

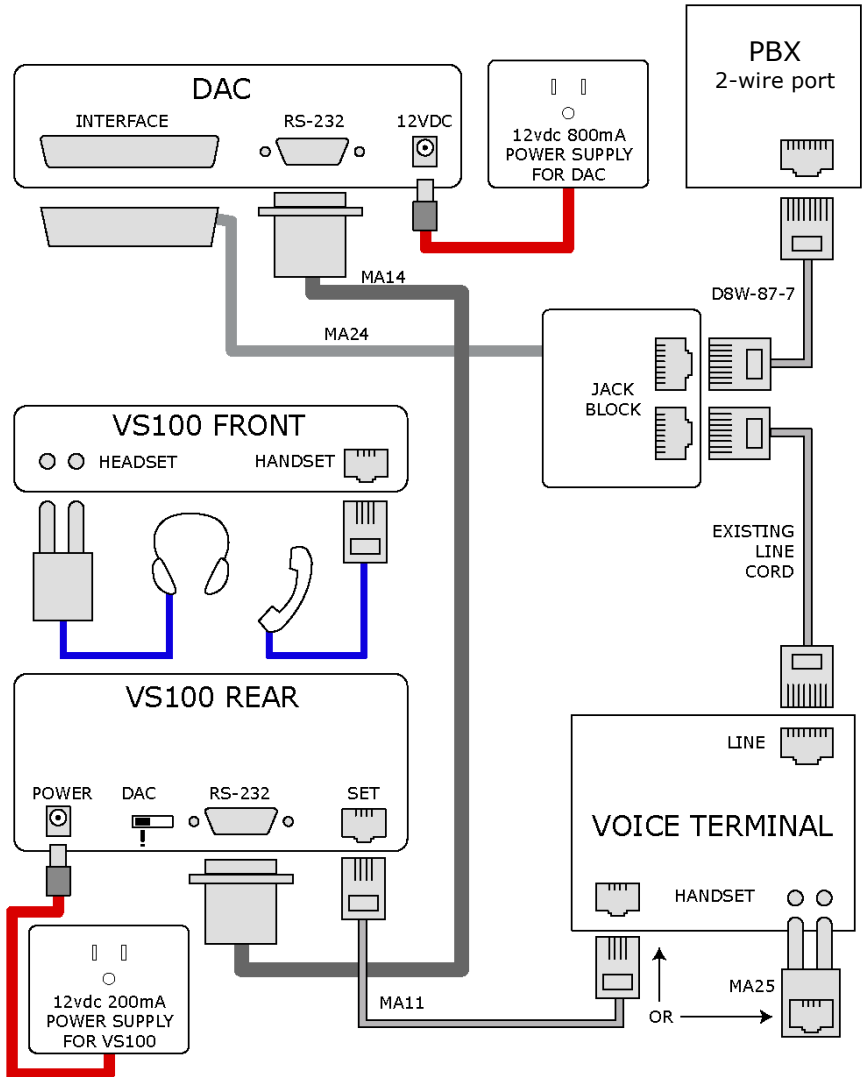
*DAC unit*

The DAC unit is powered by a 12vdc 800ma power supply. Voice terminal data is supplied by the MA24.

- 1- Plug the power supply included with the DAC unit into the **12VDC** jack. The DAC gives no indication after power is applied.
- 2- Plug the 50-pin connector from the MA24 to the jack labeled **INTERFACE** on the DAC.

The DAC has a LED indicator on the top near the power jack. This LED indicator glows red when it detects the voice terminal data. It requires 30 seconds or more to synchronize properly for data detection. Verify that this LED is turned on. If it is not, recheck the telephone connection, and verify that the telephone is still working.

When the telephone set goes off hook, the DAC red LED indicator changes to green. This indicates that the data is valid and the set is in use.

VS100

connections

- 1- Check the connection type switch on the rear of the VS100. Set the **CONNECTION** switch to **DAC**.
- 2- Set the speaker/handset switch to **SPEAKER**.
- 3- Set the run/program switch to **RUN**.
- 4- Connect the RS232 cable to the jacks marked **RS-232** on *both* the VS100 and the DAC unit.
- 5- The VS100 is powered by a 12vdc 200ma power supply. Connect the power plug to the jack marked **POWER 12VDC** on the VS100. The green LED on the front of the VS100 will start winking.

The synthesized audio can be switched from the internal speaker to the telephone handset.

- 1- Remove the handset and cord from the telephone and plug it into the VS100's **HANDSET** jack.
- 2- Plug the MA11 modular cord into the **SET** jack on the VS100.
- 3- Connect the other end of the MA11 to the voice terminal's handset jack.
- 4- Set the speaker/handset switch to **HANDSET**.

☞ If the VS100 is used to interface a Callmaster or similar set equipped with a dual prong headset jack, use the MA25 with the MA11 modular cord.

When a call comes in, the audio will not be heard if the handset is on hook. This arrangement works best if a headset is used instead of a handset and the headset is worn continuously. Plug the headset into the dual prong **HEADSET** jack on the VS100.

When the VS100 is used in the handset mode, the synthesized audio is mixed with the receive audio. The level on the synthesized audio can be adjusted with the volume control. The volume control has no effect on the telephone receive audio.

Setup

Make a station to station test call to voice the display. As soon as the called station starts ringing the display is updated with the called station information and the VS100 should voice this information.

The DAC can not detect indicators that were turned on prior to its connection. Therefore it is necessary initially to go off-hook on 2 different line buttons to properly update the VS100. This would include a message waiting indicator. If the message waiting indicator was turned on before the DAC was connected then it can not be detected until it cycles off and on, or it is updated by the PBX. The update data is sent only once per hour. New data is also sent if the telephone set is disconnected and then reconnected.

Initializing

Setup information must be sent from the VS100 to the DAC using the RS232 connection. The DAC will not output required data until it is properly initialized. If the units are powered up together, or the VS100 is powered up first, it is necessary to initialize the system.

- 1- Enter **#1** on the VS100 dial. The VS100 **ACTIVE** LED indicator will stop blinking and the initializing data is sent to the DAC.

Additional setup information is also initialized in the VS100. These settings define the voice type, speed and other factors. The setup information loads each time the unit powers up. Refer to the programming section to change the default settings.

Operation

The VS100's primary function is to voice the display messages. A message is voiced once each time the display is updated. The last message may be repeated by entering ****** on the VS100 dial.

Line busy or idle conditions can be voiced by inputting the two digit line number using the VS100 dial. A set profile for the voice terminal being used should be checked to learn how the buttons are numbered.

Held lines can be located by entering **##** on the VS100 dial. The

unit voices the word "hold" followed by any lines on hold. If no lines are on hold, it will only say "hold".

The VS100 can be reset by entering **#1**. This resets all serial data and LED indicator files. It also results in initializing data to be sent to the DAC unit.

Programming

∞ The active LED on the VS100 winks much slower when the unit is in the program mode.

Set the run/program switch to **PROGRAM**. All variables are stored using 2 digits on the VS100 dial. Digits must be entered within 3 seconds of each other. After all the variables are set, enter ***1** to save the selected parameters. If the selections are not saved, the VS100 will revert to the previous settings after a power failure. Use the test messages to test different voice parameters.

When you are finished programming the voice parameters, set the run/program switch to **RUN**.

Feature codes

Substitute the indicated digits for x. For example, dial **15** to play test message number 5.

| CODE | FEATURE | DESCRIPTION | SELECTION | DEFAULTS |
|------|--------------|---|--------------------------------------|----------|
| 1x | Test message | Play pre-stored message to test voice parameters. | 1 through 7 | |
| 2x | Voice | Select different style voices. | 1 through 8 | 1 |
| 3x | Speed | Select slow to fast speed. | Zero through 9 | 5 |
| 4x | Tone | Set the tone. | 0 = bass 1 = normal 2 = treble | 1 |
| 5x | Reverb | Include some echo. | Zero through 9 | 0 |
| 6x | Punctuation | Vary treatment of numbers and punctuation. | 1 through 4 | 1 |
| 7x | Articulation | Amount of punctuation emphasis. | 1 through 9 | 5 |
| 8x | Frequency | Changes voice characteristics. | Zero through 9 | 5 |
| *9 | Defaults | Reset features 2-8 to the factory defaults | n/a | |
| *1 | Save | Save last choice | n/a | |
| #1 | Reset | Reset the processor | n/a | |

Factory Settings

Selecting feature code *9 sets the following parameters:

| FEATURE CODE | FEATURE | DEFAULT SETTING |
|--------------|--------------|-----------------|
| 2 | Voice | 1 |
| 3 | speed | 5 |
| 4 | tone | 1 |
| 5 | reverb | 0 |
| 6 | punctuation | 1 |
| 7 | articulation | 5 |
| 8 | frequency | 5 |

Test messages

Some sample messages are stored in the unit to allow you to test changes you make to the speech parameters. These messages are not affected by the factory default (*9), or reset (#1) feature codes.

- 1- "The V, 8600 is a complete, self contained, text to speech system."
- 2- "High performance, can be attributed to a number of features, commonly found, in this type of processor."
- 3- "This is a simple test, of the VS 100, voice synthesizer."
- 4- "\$1,234.56"
- 5- "The Federal Government, has indicated that violent crime, will decrease by 3% each year, for the next 5 consecutive years."
- 6- "Birds of a feather, fly together"
- 7- "Roses are red, violets are blue, honey is sweet, and so are you."

Specifications

VS100

Size.....7.9"L x 6.15"W x 4"H

Weight.....2.0lb

Power required.....12vdc@200ma, AC adapter supplied

DAC UNIT

Size.....8"L x 8"W x 1.5"H

Weight.....1.2lb

Power required.....12vdc@800mA, AC adapter supplied

ALSO INCLUDED

1ea. MA11 cable - 2ft. length. Modular handset plug to modular handset plug. Non-coiled.

1ea. MA14 RS-232 cable - 6ft length. DB9 male to DB9 female, straight thru wiring.

1ea. MA24 interface bridge - 50 pin female amphenol with 6ft cable to 104 type connecting block with 2 bridged 8 conductor 8 position jacks.

1ea. MA25 478 modular adapter - Double tip-sleeve plug to modular handset jack. Fits standard jacks mounted on 5/8" centers. Adapts handsets or headsets equipped with modular plugs to PBX consoles.

1ea. D8W-87-7 cable - 8 position 8 conductor modular line cord (Lucent comcode #103 786 786).

Related Pec codes:

8807-105 Dual port stand alone DAC

8800-015 Braille label maker

8800-016 Braille label tapes

8800-014 VSD-1 Light Probe



Starcom Incorporated

3303 North Dixie Highway
Boca Raton, FL. 33431

phone: (561) 392-7001 ★ fax: (561) 392-7003 ★ email: info@starcom-inc.com ★ internet: www.starcom-inc.com